

# PRODUCT INFORMATION

## How to extend the life of your Spot Cooling Air Conditioner

### 9 Top Tips

to extend the life of your TradeQuip Industrial Spot Cooling Air Conditioners

Includes Models: 1031T, 1032T, 1033T

- 1** Prior to any maintenance make sure the unit is switched off and unplugged from the mains electricity supply socket.

NOTE: The electricity supplies required per model are as follows.  
1031T Runs on 240V 10A circuit  
1032T Runs on 240V 15A circuit  
1033T Runs on 240V 15A circuit

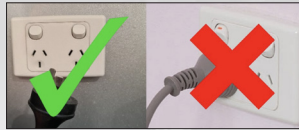

- 2** Emptying the Condensation Tank.

A 5 Litre polyethylene condensation tank in the lower-front compartment of the unit collects evaporator-coil condensation moisture.



When full, simply remove and drain.

- 3** During high humidity conditions the condensation tank will need to be emptied more frequently.

To alleviate this the Condensation Tank also comes with an optional Drain Pipe which can be installed. For information on installation instructions consult your owner's manual or at [www.tqbbrands.com.au](http://www.tqbbrands.com.au)

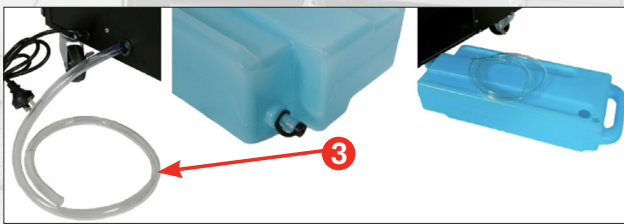

- 4** Clean the filter screen regularly using a vacuum cleaner to remove dust and dirt.

When required the filter screen can be cleaned with a cloth and luke warm water. Do not use chemicals. Leave to dry in a shaded area before reinstalling.

NOTE: For effective cooling clean the filter at least every 2 weeks.



- 5** Lubricate the castor axles and ball race to ensure smooth movement when positioning your TradeQuip Spot Cooling Air Conditioner.



- 6** Correct positioning of your TradeQuip Spot Cooling Air Conditioner is crucial to providing adequate ventilation to prevent overheating and or restricted air flow.

When the appliance is running, ensure the filter screen and the cold air ducting are 300mm minimum from the wall or other obstacles, and the hot exhaust pipe is 900mm minimum from the ceiling or other obstacles.

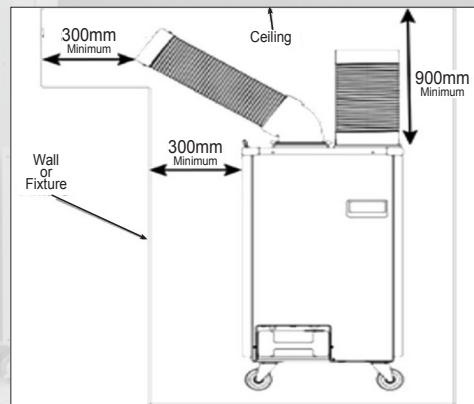

- 7** Always turn the machine off before moving it. If only moved over a very short distance ie within workshop, wait 3 minutes before restarting the machine. If transported for an extended period of time, or after first set up, allow 3 hours for the unit to settle prior to use.

- 8** Whilst not in use for extended periods we recommend following the cleaning steps one, to five outlined above leaving the Condensation Tank empty and Filter clean and ready for use next season. Always store unit in a dry environment & ensure unit is covered so its kept free of dirt & contaminants. ALWAYS STORE IN UPRIGHT POSITION.

- 9** Read the user Manual thoroughly and keep a copy easily accessible or visit our webpage [www.tqbbrands.com.au](http://www.tqbbrands.com.au) for instructional documents & pre-start videos.